



-  Bujón Ø16  
350mm.  
Cód. - 58207
-  Tuerca Ø16
-  Contratuercas



**REFERENCIAS.-**

N°	Denominación	Cant.	Material	Cod. SGA
1	Cruceta Madera 4"x10.90	1	Madera	061619
	Cruceta Madera 4"x1.5	2	Madera	
2	Bulon Ø16x350mm. tuerca y contratuercas	6	Aluminio.	057868

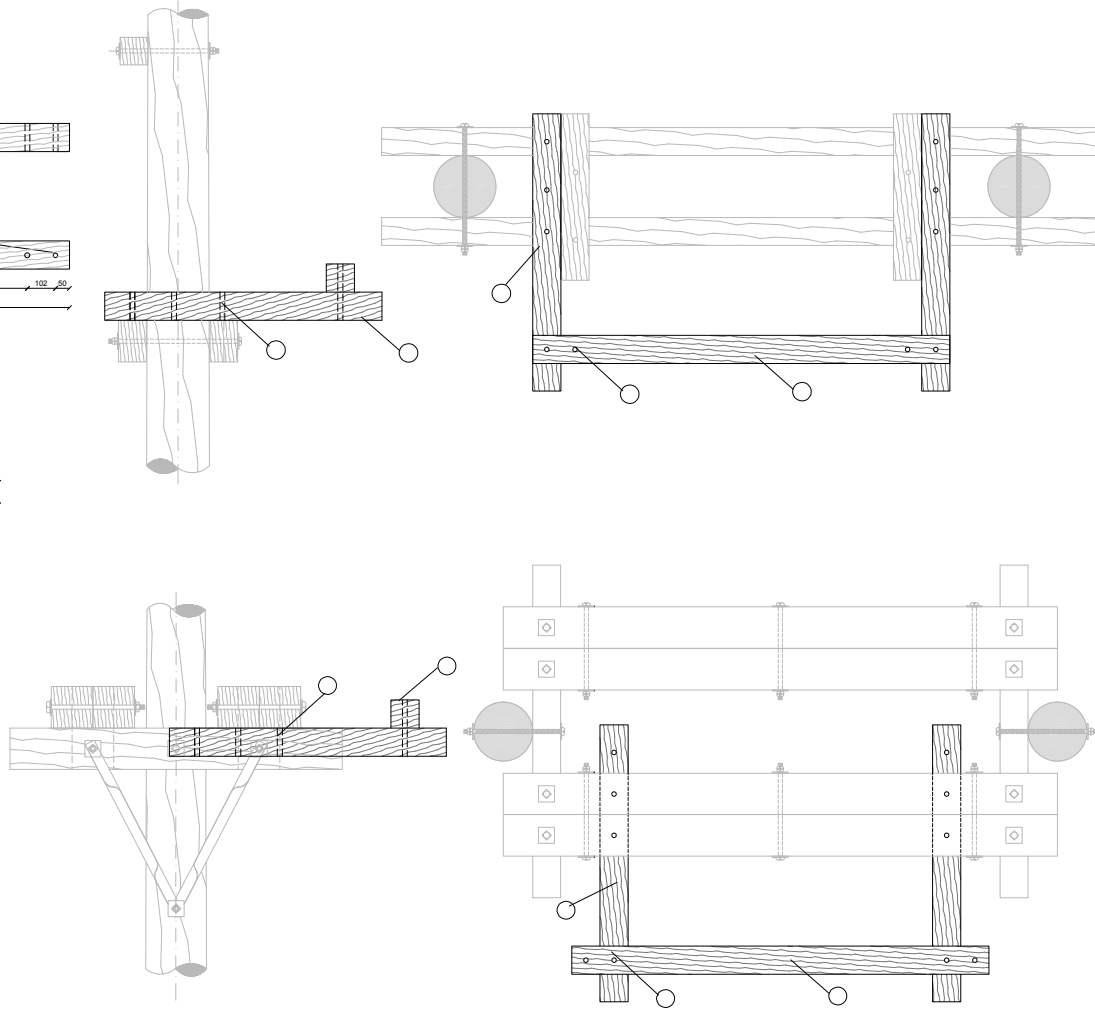
\* Medidas expresadas en mm.



Polo de la Luz P/5 Tel 2090540 Fax: 2083084 - nord@ute.com.uy - proy@ute.com.uy - pcyra.ed@ute.com.uy

APOYA ESCALERA EN SEA 2 APOYOS ZONA POLLIDA

ZONA POLLIDA SEA EN 2 APOYOS-MADERA Y ALUMINIO			1:10
09/03	M. Pérez	D. Martínez	061619
AA-DIBUJ/D-SBA/SBA MADERA/ESCUADRIAS/			